

## JMB Spring Return Guide Post: Driven Ground Spike - Installation Instructions

The JMB GS001 Ground Spike is designed for installing into the ground. It is mainly used on the side of roadways or locations where mounting is required in the earth

### 1) Safety

Always use traffic control appropriate to the location to make the work area safe for installation

### 2) Prepare the Site

Follow any local authority guidelines for positioning the guide post, post or delineator blade

### 3) Positioning the Ground Spike

Position the Ground Spike aligning the traffic flow arrows on the spike with the actual traffic flow on the road. *(This positions the "Twist and Lock" connection system in the correct orientation.)*

Refer Figure 1

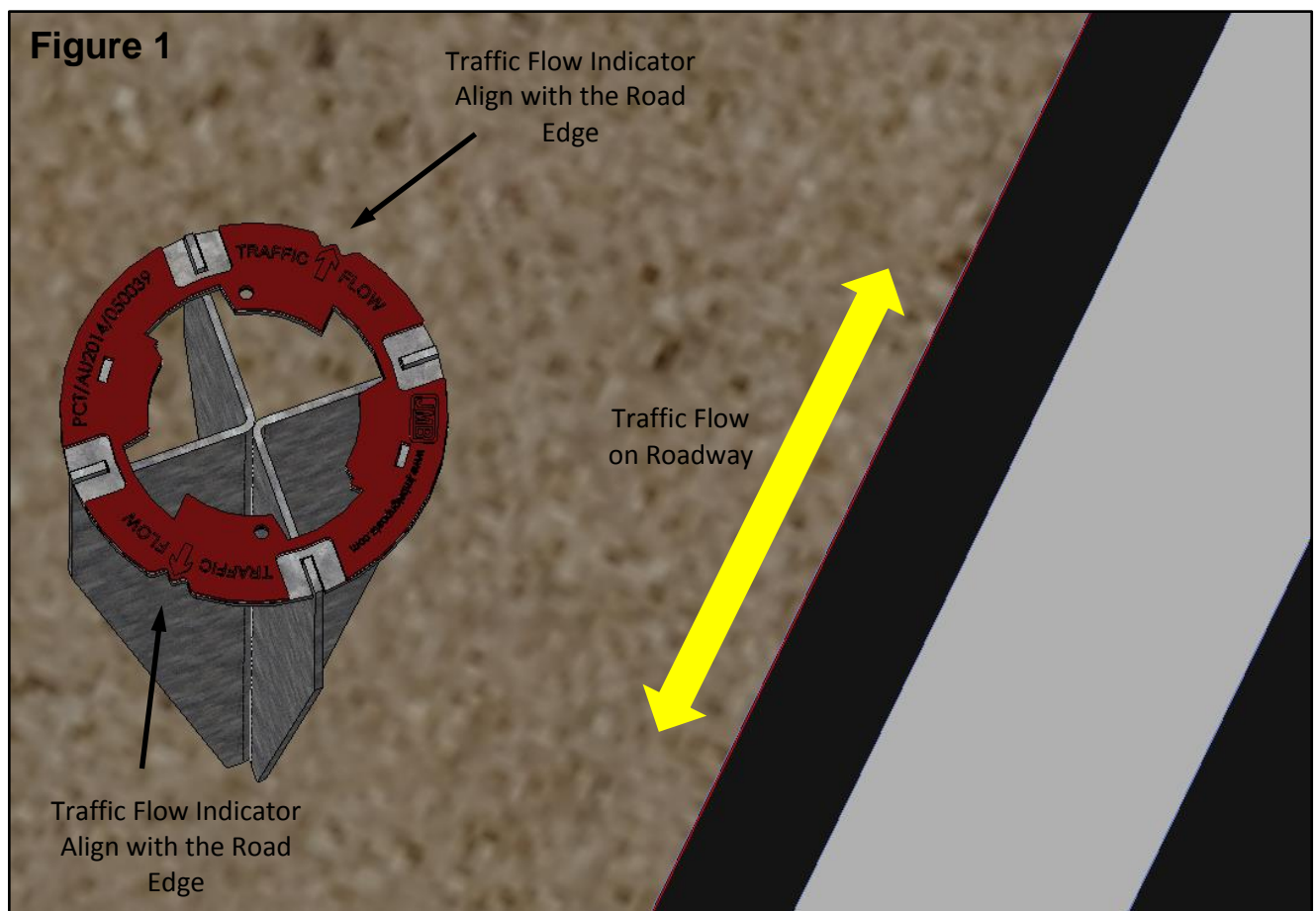

## JMB Spring Return Guide Post: Driven Ground Spike - Installation Instructions cont.

### 4) Preparing the Ground Spike – Manual Method

The GS001D Driving Tool is used to safely drive the ground spike without damage.

**IMPORTANT:** REMOVE THE PLASTIC SPACER

Insert the GS001D Driving Tool into the Ground Spike by passing it through the top plate of the spike, and then twist it to lock it under the top plate. The 2 parts will lock together and act as one.

Refer Figure 2

The GS001D driving tool can be used “Manually” with a Hammer or can be fitted with the GS001E Jack Hammer adaptor for “Mechanical Driving” with a 30mm Hex Jack Hammer. Refer Figures 5 & 6 for Mechanical Driving.

Each Driving method is explained separately in the following instructions.

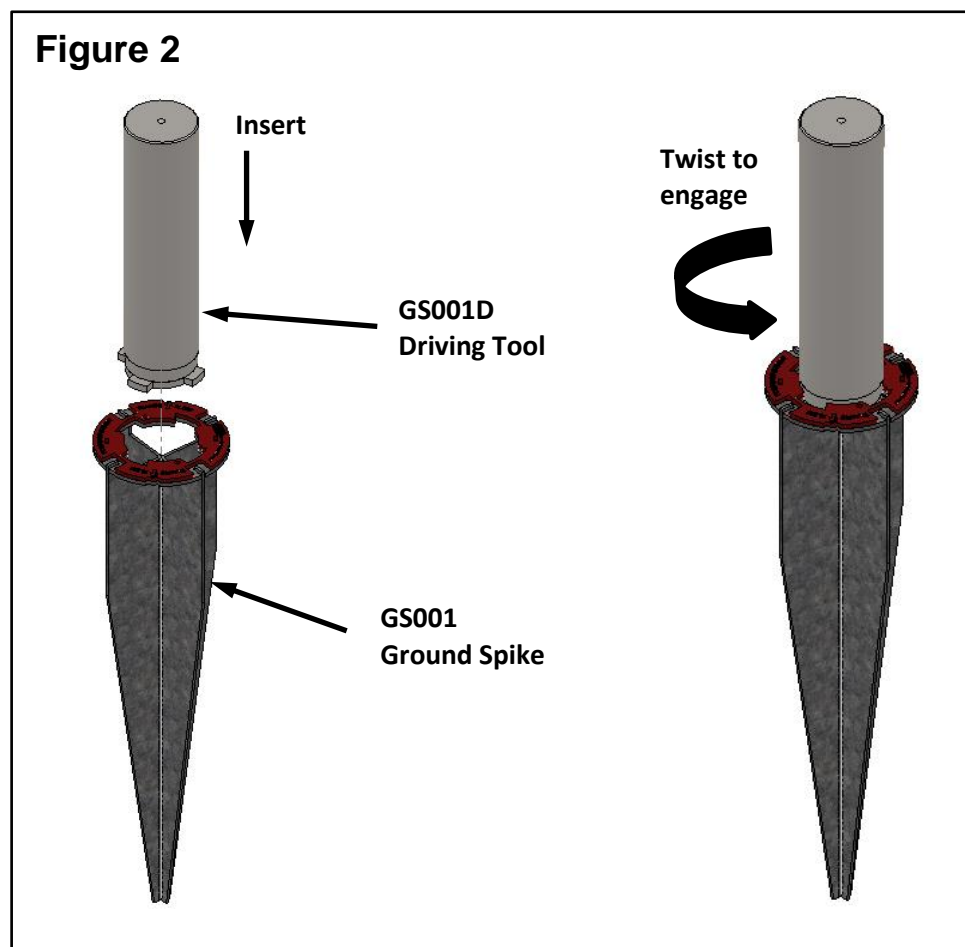

## JMB Spring Return Guide Post: Driven Ground Spike - Installation Instructions cont.

### 5) Manual Driving of the Ground Spike

Mark the position of the post following local regulations.

Insert the GS001D Driving Tool into the Ground Spike and twist it to lock it under the ground spike top plate.

Position the point of the spike in the correct position and align the traffic flow markers with the road edge.

Drive the ground spike using a sledge hammer or similar as shown in Figure 3 below for 10 - 20mm.

Ensure the ground spike is correctly orientated and vertical.

Keep driving and checking alignment as the Spike is installed to ensure the guide post will be vertical when installed.

Drive the spike until it is flush to the ground or a few millimetres above.

Rotate the Driving Tool as you disconnect it from the ground spike to clear the dirt in the "Turn and Lock" area so the post can be fitted. Refer to Figures 7 to 10 for post fitment

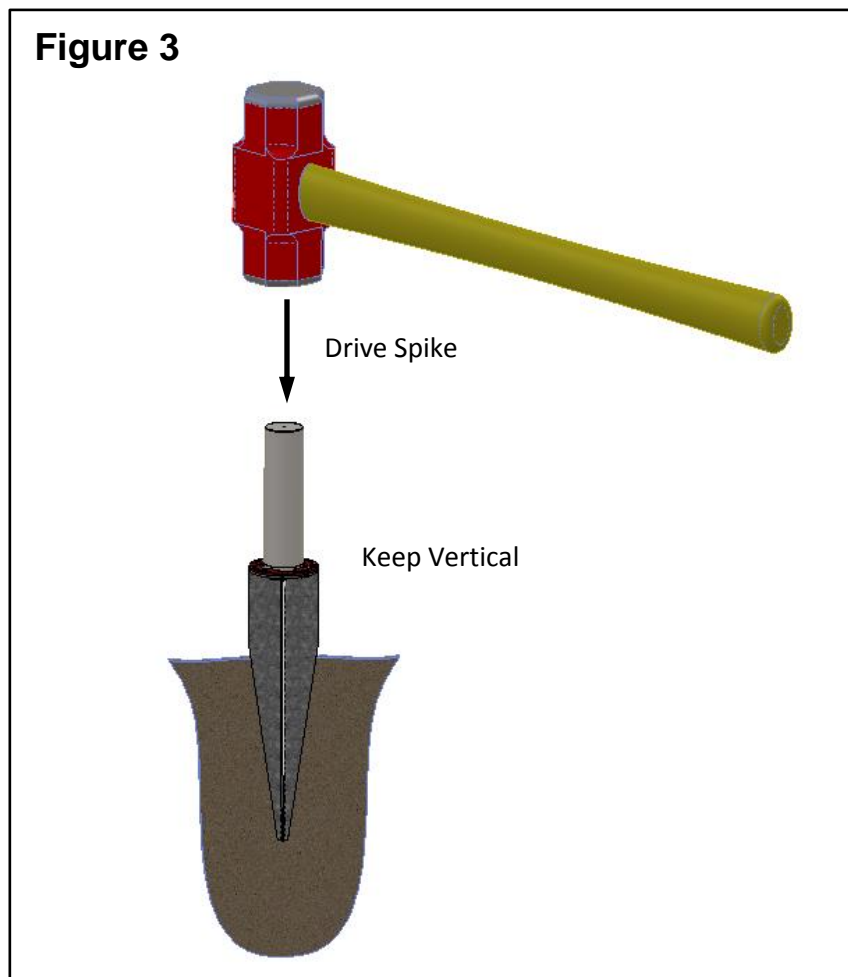

## JMB Spring Return Guide Post: Driven Ground Spike - Installation Instructions cont.

### 6) Preparing the Ground Spike – Mechanical Method

The GS001D Driving Tool is used to safely drive the ground spike without damage.

The GS001D Driving Tool can be assembled with the GS001E 30mm-Hex Jack Hammer Adaptor to allow the ground spike to be mechanically driven using a Jack Hammer. Lock the two together by tightening the locking bolt and then the secondary locking nut.

**IMPORTANT: REMOVE THE PLASTIC SPACER**

Insert the GS001D & GS001E Driving assembly into the Ground Spike by passing it through the top plate of the spike, and then twist it to lock it under the top plate. The 2 parts will lock together and act as one.

Refer Figure 5

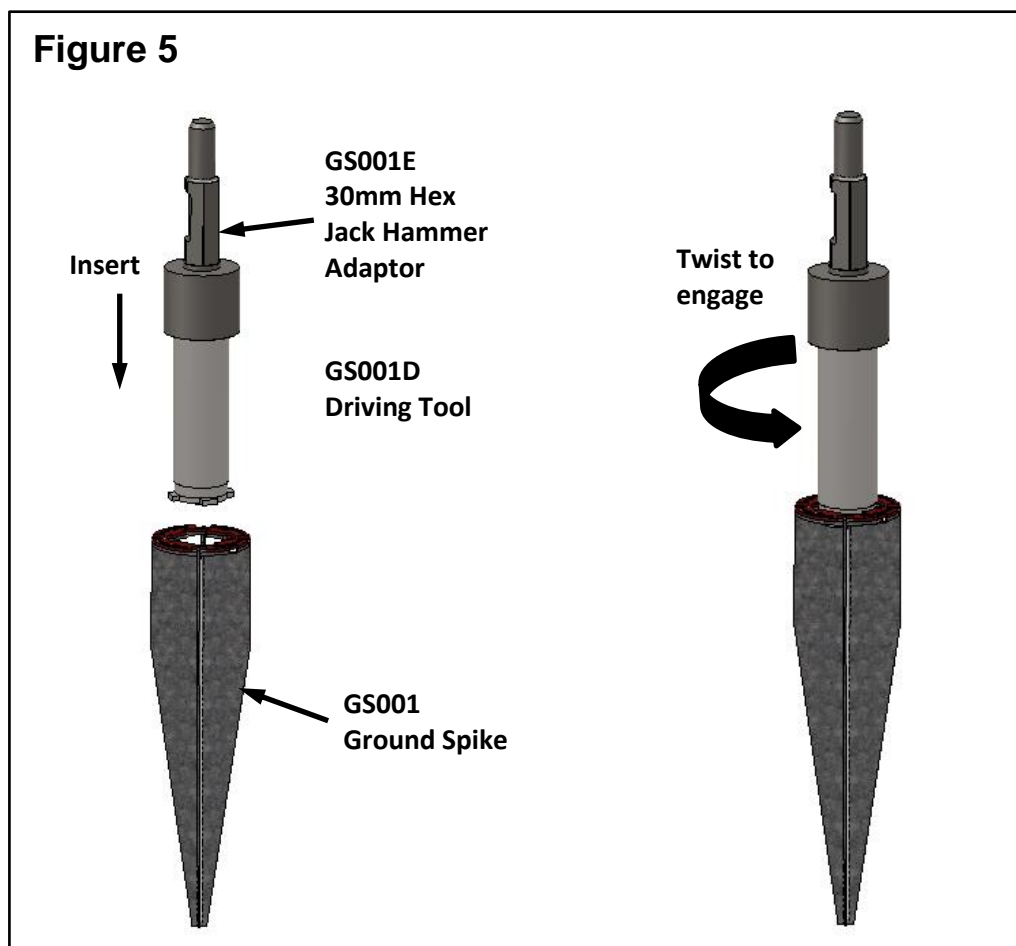

## JMB Spring Return Guide Post: Driven Ground Spike - Installation Instructions cont.

### 5) Driving of the Ground Spike – *(Mechanical: Jack Hammer Method)*

Mark the position of the post following local regulations.

Insert the Jack Hammer and Driving Tool Assembly into the Ground Spike. Twist it to lock it under the ground spike top plate.

Position the point of the spike in the correct position and align the traffic flow markers with the road edge.

Drive the ground spike using the Jack Hammer as shown in Figure 6 below.

Use the Jack Hammer to ensure the ground spike is correctly orientated and remains vertical.

Drive the spike until it is flush to the ground or a few millimetres above.

Rotate the Driving Tool as you disconnect it from the ground spike to clear the dirt in the “Turn and Lock” area so the post can be fitted. Refer to Figures 7 to 10 for post fitment

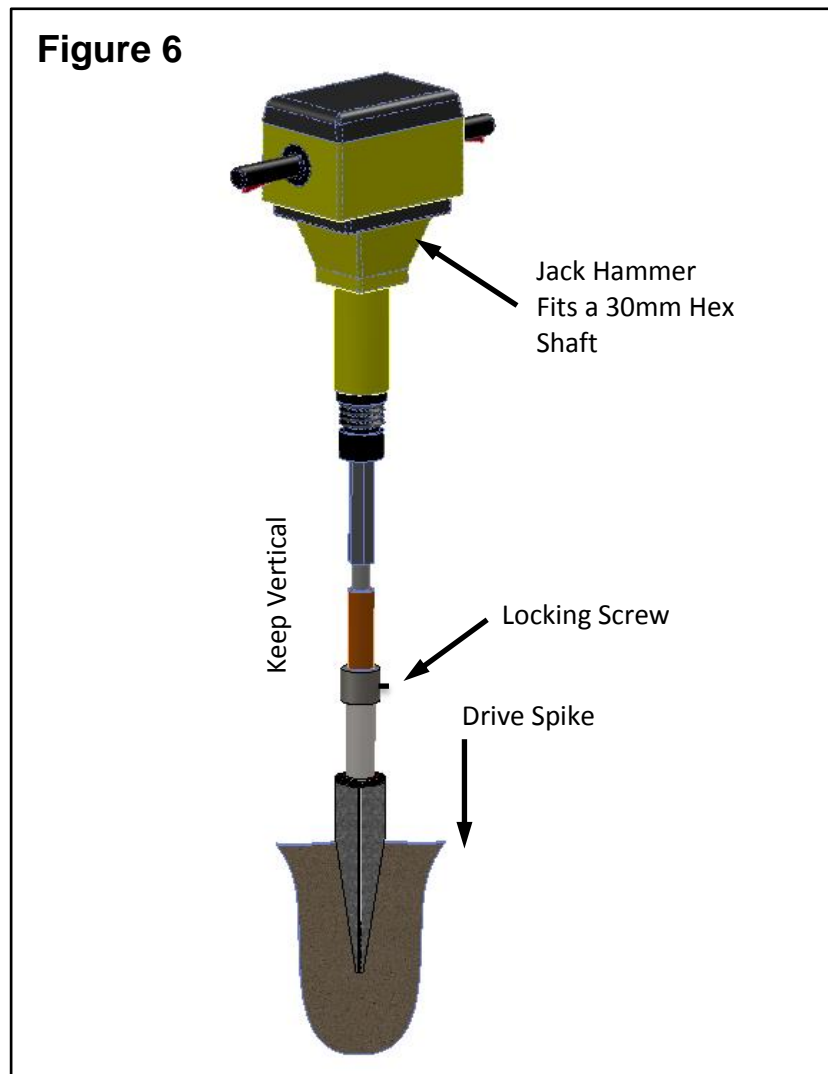

## JMB Spring Return Guide Post: Driven Ground Spike - Installation Instructions cont.

### 6) Installing the Guide/ Delineator Post

Once the ground spike has been driven re-fit the plastic spacer onto the top plate. The guide post can now be fitted. JMB Spring Return Guide Posts use our simple Turn and Lock™ system to connect to the ground spike. Both Installation and replacement only takes seconds.

The Turn and Lock™ system is keyed to ensure the correct blade orientation. A 7g locking screw or pin can be used to prevent accidental disconnection. Refer to the following Figures 7 to 10 below.

**Figure 7: Step 1**

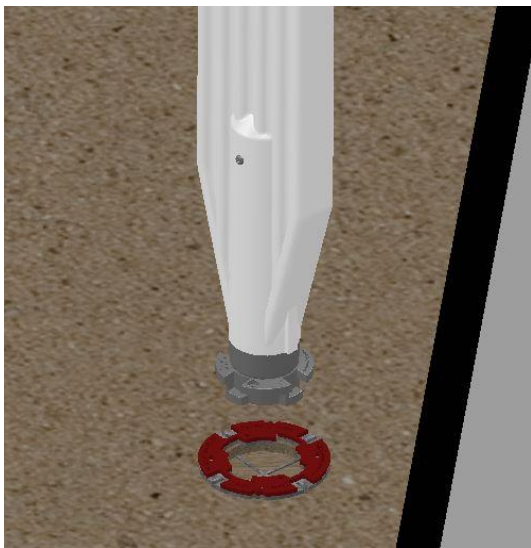

Position the post above the spike aligning the locating peg

**Figure 8: Step 2**

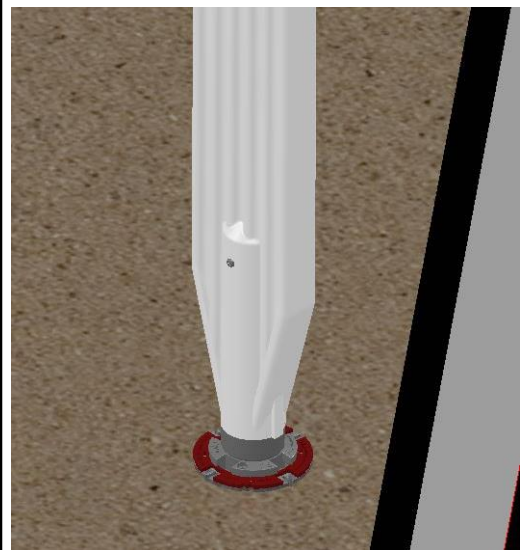

Insert into the hole

**Figure 9: Step 3**

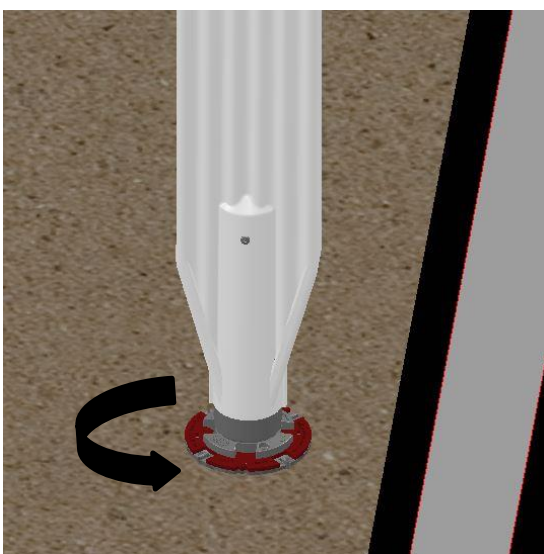

Turn the post and lock.

**Figure 10: Step 4**

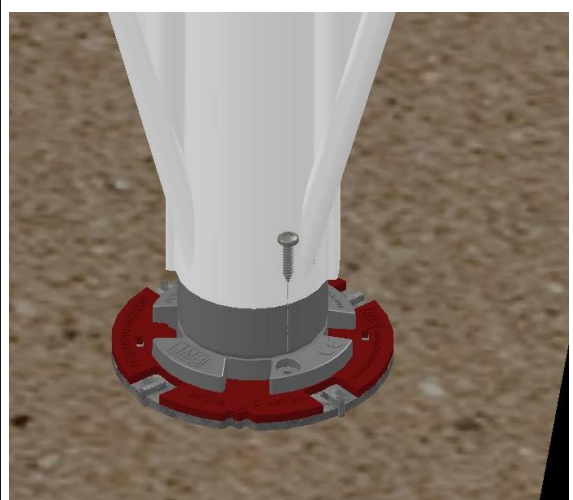

Fit a locking Screw or Pin  
Screw: Pan Head 6g x 16mm or 7g x 16mm  
Pin: 3mmOD x 12mm (minimum)

## JMB Spring Return Guide Post: Driven Ground Spike - Installation Instructions cont.

### 8) Completed Installation

The GS001 Ground Spike can be used with any Post element that is fitted with the G2100201 “Turn and Lock” Base Unit. Refer Figure 11

Once Installed each Spring Return Delineator Blade or Post is passive safe and features full 360° impact recovery.

Post removal or replacement takes only seconds

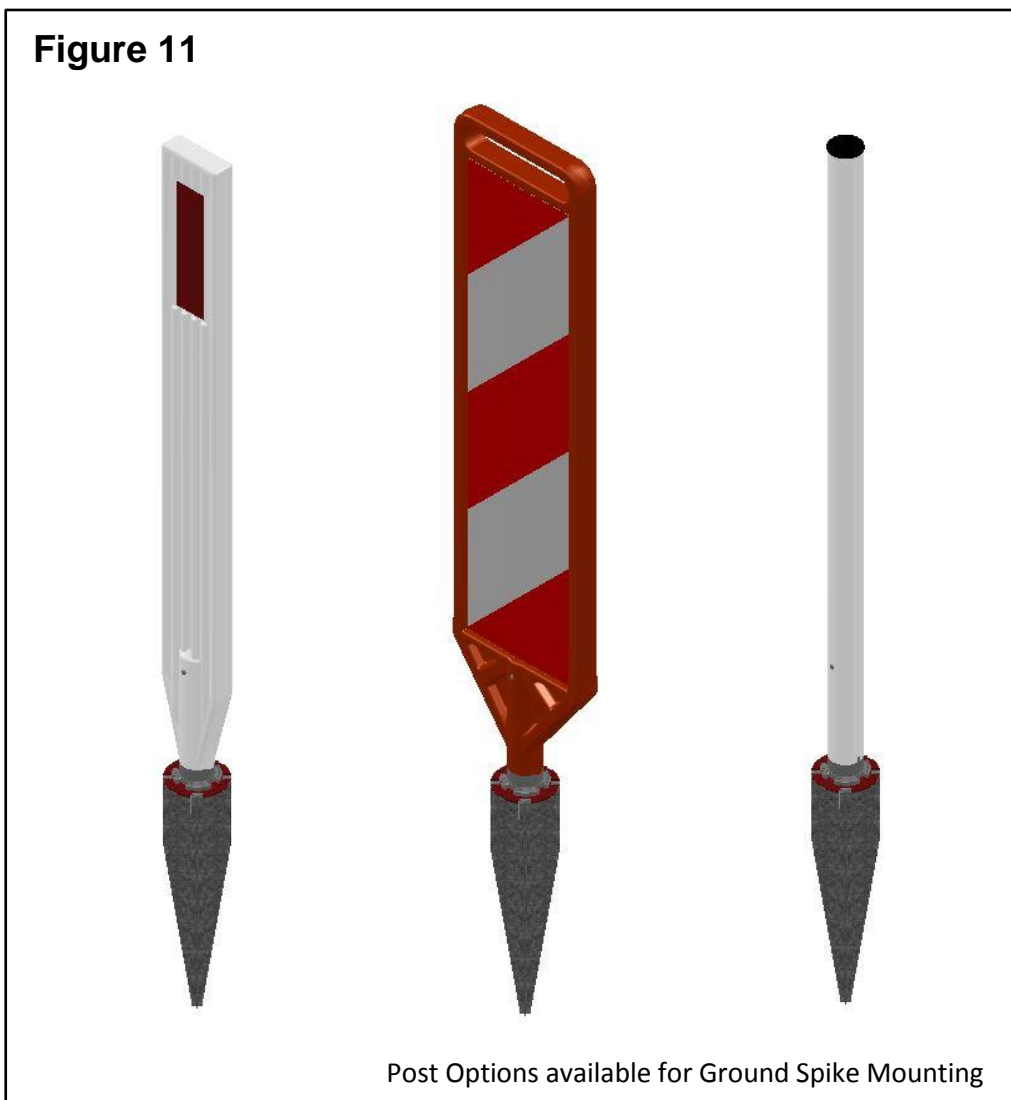

### REFERENCE INFORMATION:

General Installation and Dimensional information can also be found in the “Generation 2 Products – Technical Information” Available for download off the JMB website downloads page.